

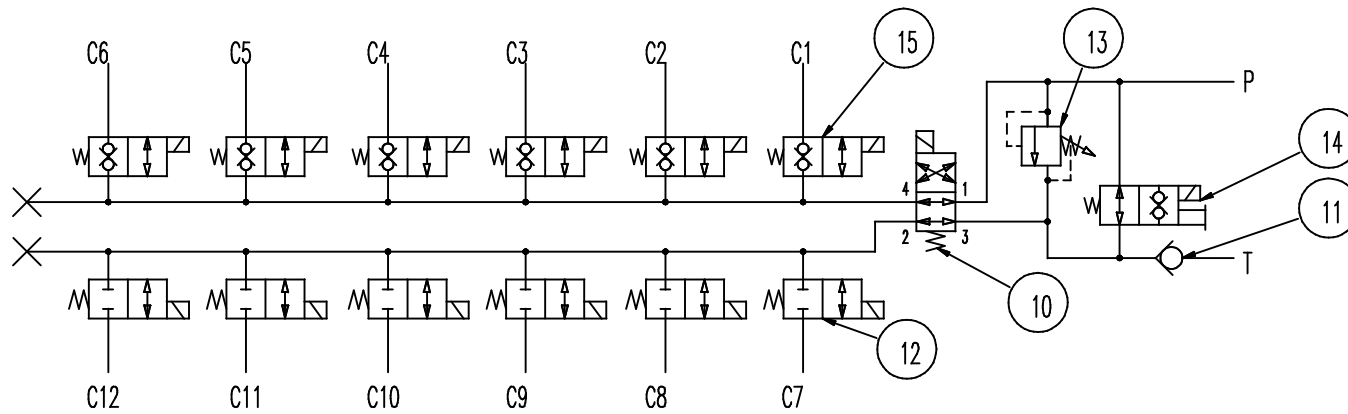

# HYDRAULIC SCHEMATICS



UNLESS OTHERWISE SPECIFIED DIMENSIONS ARE IN INCHES TOLERANCES ON: 2 PL. DECIMALS 3 PL. DECIMALS ANGLES FRACTIONS	SIGNATURES	DATE	 <b>FASSE VALVES</b> SEVEN ROVAR PARK KEARNEY, NE 68848-2348
	DRAFTER DLG	08/07/13	
	ENGRG BWL	08/07/13	MANI ASSY 0806 6DA CLSD 12V DTR WP6400-6 PT6801-8
THIS DRAWING IS A PROPRIETARY DESIGN OWNED BY FBS CORPORATION/FASSE VALVES AND IS SUBMITTED UNDER A CONFIDENTIAL RELATIONSHIP. EXCEPT FOR USES EXPRESSLY GRANTED IN WRITING, ALL RIGHTS ARE RESERVED BY FASSE VALVES.		FSCM NO	DWG NO 302-593
		SCALE	SHEET 2 OF 2

PARTS LIST

REF.	PART NO.	QTY.	DESCRIPTION
1	210-017	2	FTG 6801-8-8/E-MF-MO
2	210-023	4	FTG 6400-6-6/S-MJ-MO
3	210-113	8	FTG 6400-4-6/S MJ-MO
4	213-516	1	COIL CAP MANUAL OVERRIDE SV10-21P
5	232-050	2	DECL S/N (SILVER)
6	232-058	1	DECL GOLD/BLK 1.5 X .5
7	253-590	12	COIL H/F 4304012 E-8 INTG DEUT DTR 12V ZENER DIODE
8	253-593	2	COIL H/F 4304112E-10 INTG DEUT DTR 12V ZENER DIODE
9	270-192	1	MANI S16266-1 6CIR AL
10	273-008	1	CART H/F SV10-40-0-N-00 SPL 4W 2P
11	273-014	1	CART CV10-20-0-N-5
12	273-016	6	CART SV08-24-0-N-00
13	273-182	1	CART H/F RV10-22H-0-NC-35/32 RLF DIFF AREA POP 3200PS
14	273-357	1	SV10-29P-0-N-00 POP NO BI-DIR MAN
15	273-500	6	CART H/F SV08-28-0-N-00 2P POP NC BI-DIR

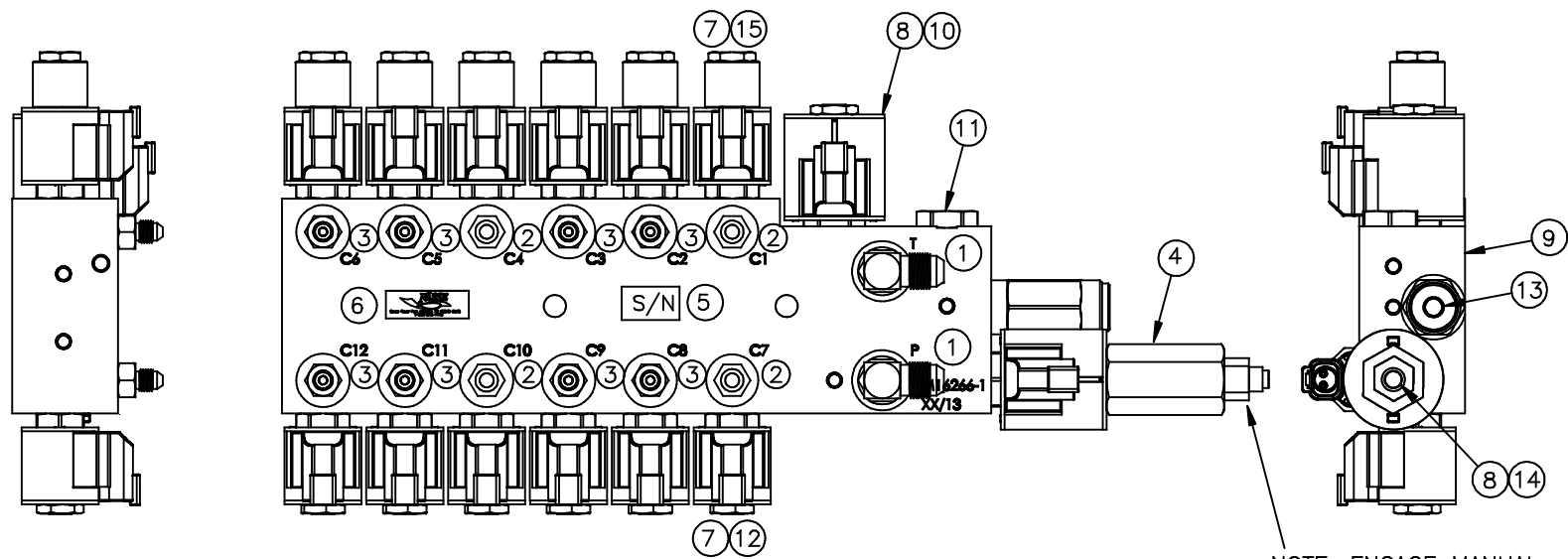

REVISIONS					UNLESS OTHERWISE SPECIFIED		SIGNATURES		DATE		 <b>FASSE VALVES</b> SEVEN ROVAR PARK KEARNEY, NE 68848-2348	
REV	DESCRIPTION	FORM #	DATE	APPROVED	DIMENSIONS ARE IN INCHES TOLERANCES ON: 2 PL. DECIMALS 3 PL. DECIMALS ANGLES FRACTIONS		DRAFTER	DLG	08/07/13		MANI ASSY 0806 6DA CLSD 12V DTR WP6400-6 PT6801-8	
	RELEASED DRAWING	13-0065	08/07/13	DLG BWL			ENGRG	BWL	08/07/13		FSCM NO	DWG NO 302-593
THIS DRAWING IS A PROPRIETARY DESIGN OWNED BY FASSE CORPORATION/FASSE VALVES AND IS SUBMITTED UNDER A CONFIDENTIAL RELATIONSHIP. EXCEPT FOR USES EXPRESSLY GRANTED IN WRITING, ALL RIGHTS ARE RESERVED BY FASSE VALVES.											SCALE	SHEET 1 OF 2

PARTS LIST

REF.	PART NO.	QTY.	PART DESCRIPTION
1	210-038	2	FTG 6408-HHP-8/HOLL HEX PLUG MO
2	210-127	2	FTG 6408-HHP-6/HOLL HEX PLUG MO
3	210-151	6	FTG 6410-6-6/S-MO-FO
4	210-166	2	FTG 6901-8-6 /E-MO-FPSW
5	210-189	8	FTG 6901-6-4/E-MO-FPSW
6	210-229	4	FTG 6901-6-6/E-MO-FPSW
7	232-050	2	DECL S/N (SILVER)
8	232-058	1	DECAL FASSE BLK/GOLD 1"X.75" RND CRNR
9	253-590	12	COIL H/F 4304012 E-8 INTG DEUT DTR 12V ZENER DIODE
10	253-593	2	COIL H/F 4304112E-10 INTG DEUT DTR 12V ZENER DIODE
11	270-011	1	MANI S14259-1 7CIR AL
12	273-008	1	CART H/F SV10-40-0-N-00 SPL 4W 2P
13	273-012	1	CART H/F CP10-20-N CAVITY PLUG 2W
14	273-016	6	CART SV08-24-0-N-00
15	273-017	1	CART SV10-21-0-N-00
16	273-078	1	CART H/F RV10-22H-0-N-35 REL DIFF AREA POP 3000PSI
17	273-500	6	CART H/F SV08-28-0-N-00 2P POP NC BI-DIR
18	279-008	1	CHK VLV 10301-503

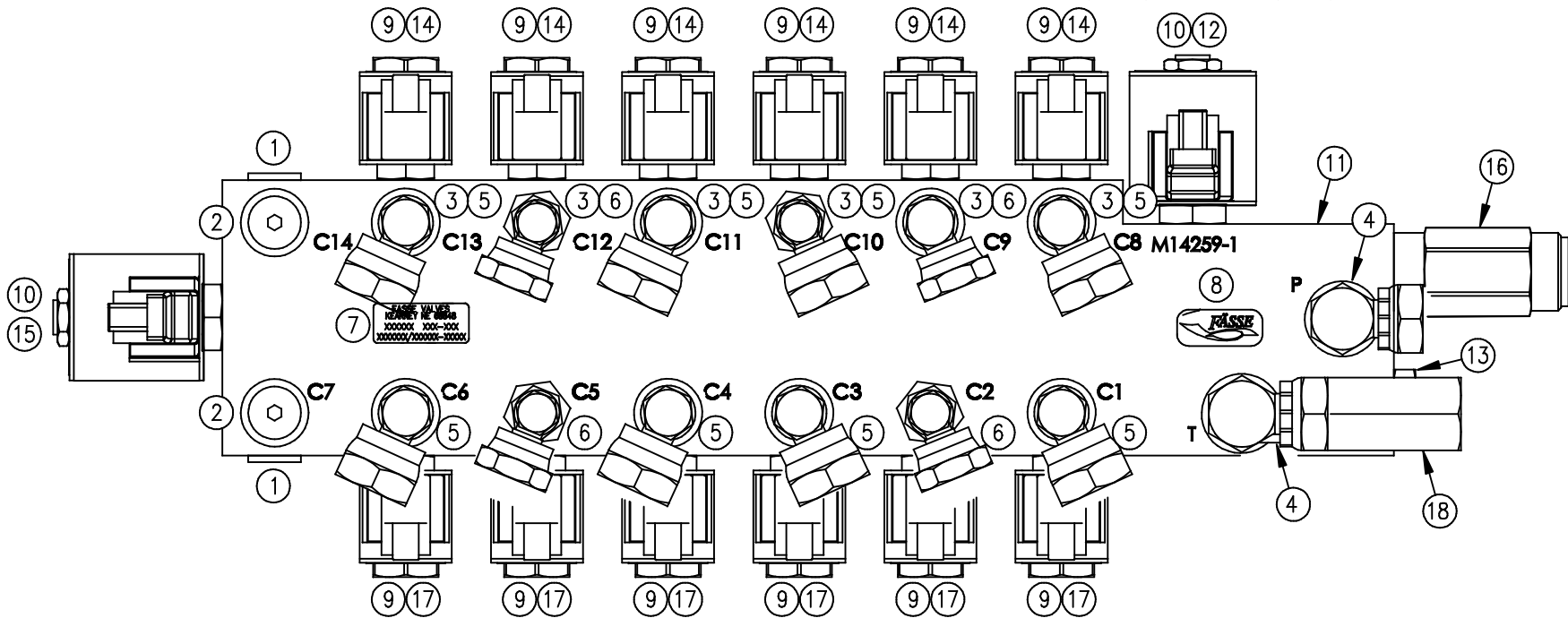

REVISIONS					UNLESS OTHERWISE SPECIFIED		SIGNATURES		DATE	
REV	DESCRIPTION	FORM #	DATE	APPROVED	DIMENSIONS ARE IN INCHES TOLERANCES ON:		DRAFTER			
	RELEASED DRAWING	13-0085	12/16/13	DLG	2 PL DECIMALS		DLG	12/16/13		
A	REVISED DRAWING	14-0076	10/7/14	DLG	3 PL DECIMALS ANGLES FRACTIONS		ENGRG	12/16/13		

  

		<b>FASSE VALVES</b> SEVEN ROVAR PARK KEARNEY, NE 68848-2348	
MANI ASSY 0806 6DA CLSD E-INTG DTR 12V WP6901-6 PT6901-6			
SIZE	FSCM NO	DWG NO	
A		302-616	
SCALE			SHEET

THIS DRAWING IS A PROPRIETARY DESIGN OWNED BY FBS CORPORATION/FASSE VALVES AND IS SUBMITTED UNDER A CONFIDENTIAL RELATIONSHIP. EXCEPT FOR USES EXPRESSLY GRANTED IN WRITING, ALL RIGHTS ARE RESERVED BY FASSE VALVES.

PARTS LIST

QTY	PART NUMBER	PART DESCRIPTION
1	212-025	BOLT 5/16-18X0.75
16	214-002	CABLE TIE BLACK 7"
1	255-026	LOOM CLAMP .5"ID METAL/RUBR
1	302-616	MANI ASSY 0806 6DA CLSD E-INTG DTR 12V WP6901-6 PT6901-6
1	312-076	HRN ASSY 19CON 18GA DTR 12P(12) DTR 8P(7) 15DTP 2P(2) 25'

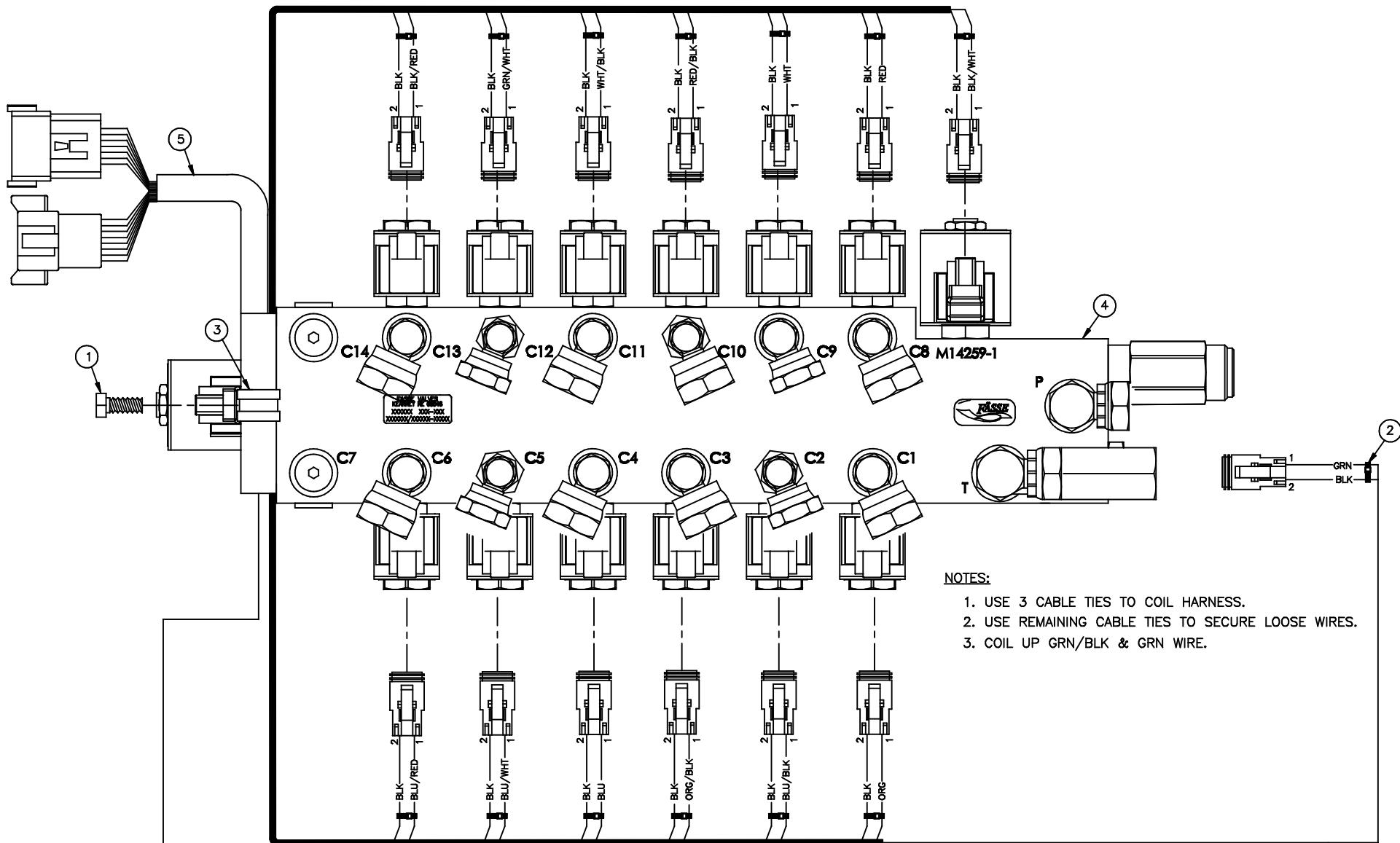

NOTES:

1. USE 3 CABLE TIES TO COIL HARNESS.
2. USE REMAINING CABLE TIES TO SECURE LOOSE WIRES.
3. COIL UP GRN/BLK & GRN WIRE.

GRN/BLK

REVISIONS					UNLESS OTHERWISE SPECIFIED		SIGNATURES		DATE
REV	DESCRIPTION	FORM #	DATE	APPROVED	DIMENSIONS ARE IN INCHES	DRAFTER	DATE	DATE	
	RELEASED DRAWING	13-0085	08/07/13	DLG BWL	2 PL DECIMALS	DLG	08/07/13		
A	UPDATED DRAWING	13-0085	12/17/13	DLG BWL	3 PL DECIMALS	ENGRG	08/07/13		
					FRACTIONS				
					ANGLES				
					THIS DRAWING IS A PROPRIETARY DESIGN OWNED BY FASSE CORPORATION/FASSE VALVES AND IS SUBMITTED UNDER A CONFIDENTIAL RELATIONSHIP. EXCEPT FOR USES EXPRESSLY GRANTED IN WRITING, ALL RIGHTS ARE RESERVED BY FASSE VALVES.				
					SIZE		FSCM NO		DWG NO
					A				303-167
					SCALE				SHEET

**FASSE** FASSE VALVES  
SEVEN ROVAR PARK  
KEARNEY, NE 68848-2348

MANI/HRN ASSY 0806 6DA CLSD 12V  
DTR WP6901-6 PT6901-6 19CON DTR  
12P(12) DTR 8P(7) 25'

PARTS LIST

QTY	PART NUMBER	PART DESCRIPTION
4"	231-006	SHRINKTUBING .375" BLK DUAL WALL
2"	231-007	SHRINKTUBING .625
4"	231-008	SHRINKTUBING .750
2"	231-013	SHRINKTUBING .250" BLK DUAL WALL
23"	231-187	SHRINKTUBING .187 BLK
27"	252-004	CABLE 19CON 18GA PVC GRY
17"	252-058	WIRE 18GA BLK
1	255-212	CONN DEUT DT RCPT 12PIN
1	255-214	CONN DEUT LOCK WEDGE 12PIN DTR GRN
1	255-218	CNTR DEUTSCH 8PIN RECPT DT
1	255-220	CNTR DEUTSCH LOCKWEDGE 8PIN DTR
15	255-505	CNTR DEUTSCH LOCKWEDGE 2PIN DTP
15	255-801	CNTR DEUTSCH 2PIN PLUG DT
19	255-977	TRM PIN DEUTSCH 16/18GA
30	255-978	CNTR DEUTSCH SOCKET 16/18GA
1	255-979	CONT DEUT CAVITY PLUG

PIN OUT DETAIL 8

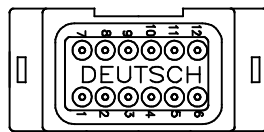

- 1 - RED/WHT
- 2 - GRN/BLK
- 3 - BLU/BLK
- 4 - WHT
- 5 - BLU/WHT
- 6 - GRN/WHT
- 7 - ORG/BLK
- 8 - RED/BLK
- 9 - BLU/RED
- 10 - BLU
- 11 - ORG/RED
- 12 - ORG

PIN OUT DETAIL 10

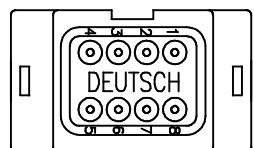

- 1-WHT/RED
- 2-RED
- 3-WHT/BLK
- 4-BLK/WHT
- 5-GRN
- 6-BLK/RED
- 7-BLK
- 8-CAVITY PLUG

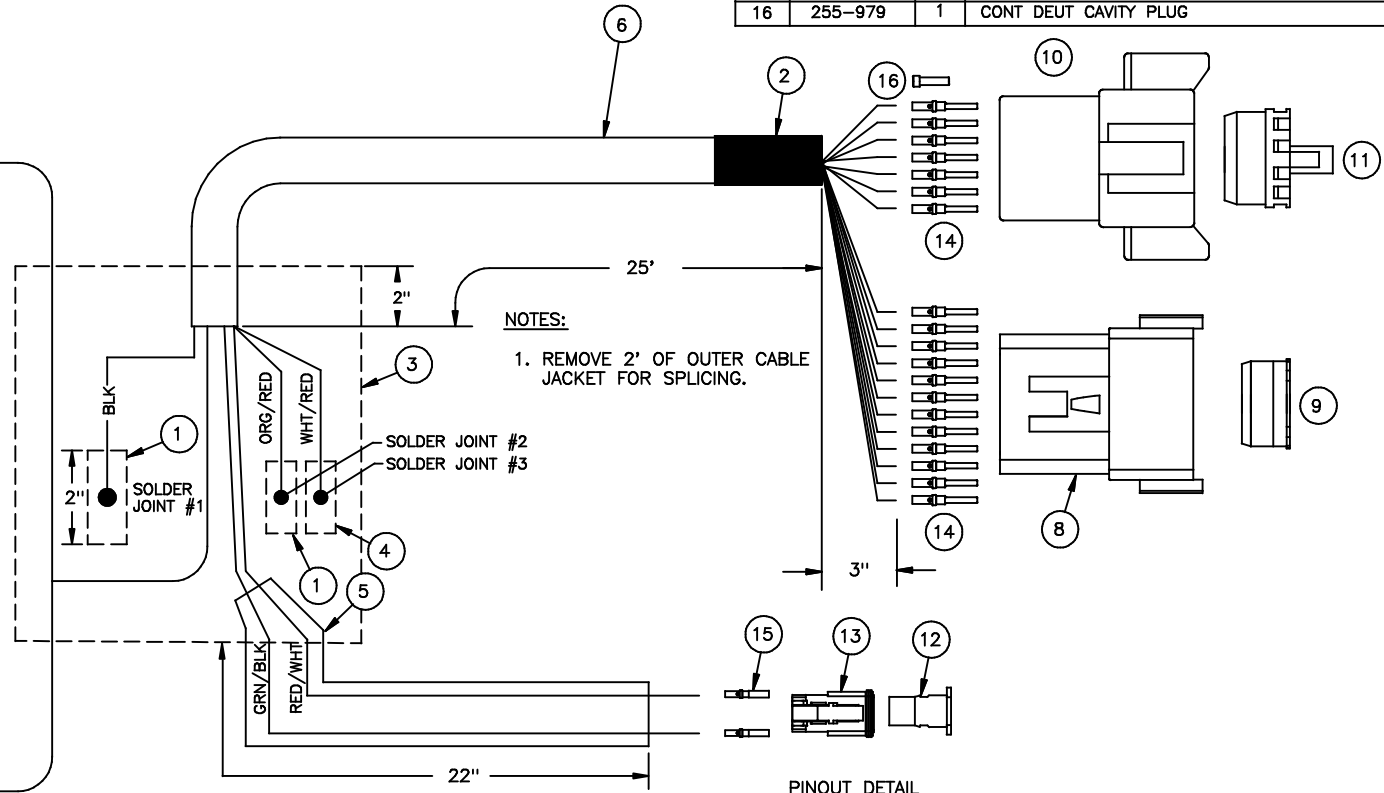
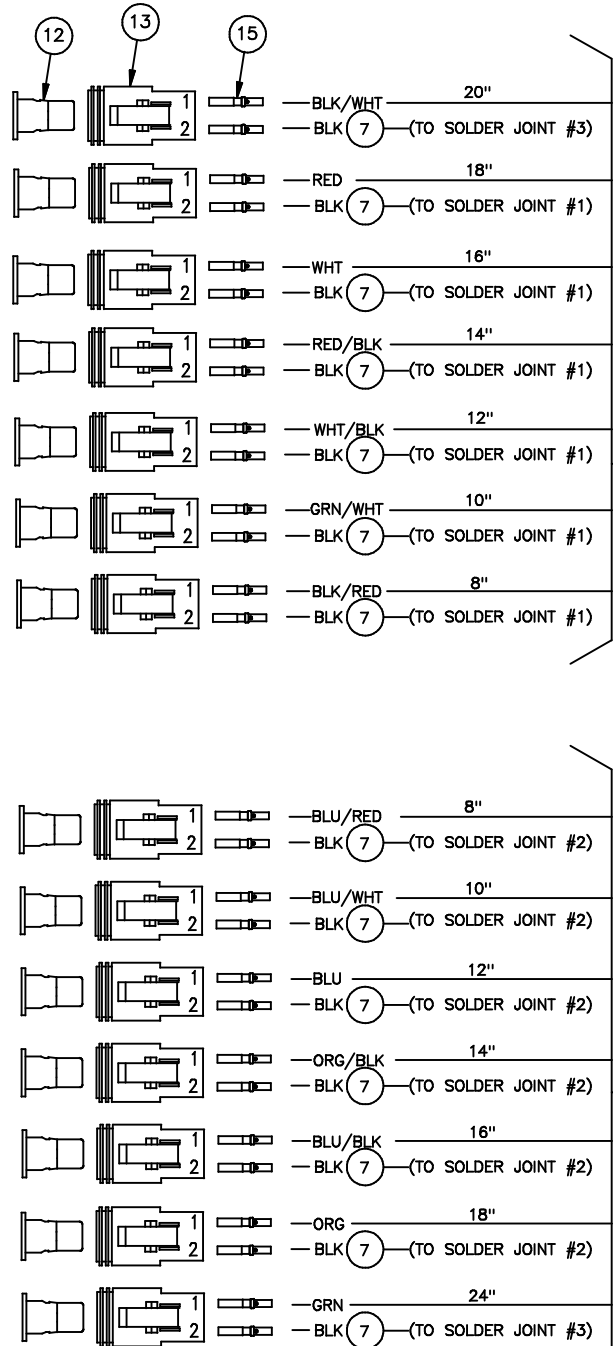

PINOUT DETAIL (DEUT PLUG)

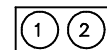

- 1 = GRN/BLK
- 2 = RED/WHT

REVISIONS					UNLESS OTHERWISE SPECIFIED		SIGNATURES		DATE	
REV	DESCRIPTION	FORM #	DATE	APPROVED	DIMENSIONS ARE IN INCHES	DRAWER	DLG	DATE		
	RELEASED DRAWING	13-0085	08/07/13	DLG BHL	TOLERANCES ARE ON:			08/07/13		
A	REVISED DRAWING	14-0013	3/25/14	DLG BHL	2 PL. DECIMALS					
B	REVISED DRAWING	15-0040	5/27/15	DLG BHL	3 PL. DECIMALS					
					ANGLES					
					FRACTIONS					

  

THIS DRAWING IS A PROPRIETARY DESIGN OWNED BY FASSE CORPORATION/FASSE VALVES AND IS SUBMITTED UNDER A CONFIDENTIAL RELATIONSHIP. EXCEPT FOR USES EXPRESSLY GRANTED IN WRITING, ALL RIGHTS ARE RESERVED BY FASSE VALVES.		FSCM NO SCALE	DWG NO 312-076 SHEET
---	--	------------------	----------------------------

FASSE VALVES  
SEVEN ROVAR PARK  
KEARNEY, NE 68848-2348

HRN ASSY 19CON 18GA DTR 12P(12)  
DTR 8P(7) 15DTP 2P(2) 25'

### SWITCH WIRING DIAGRAM

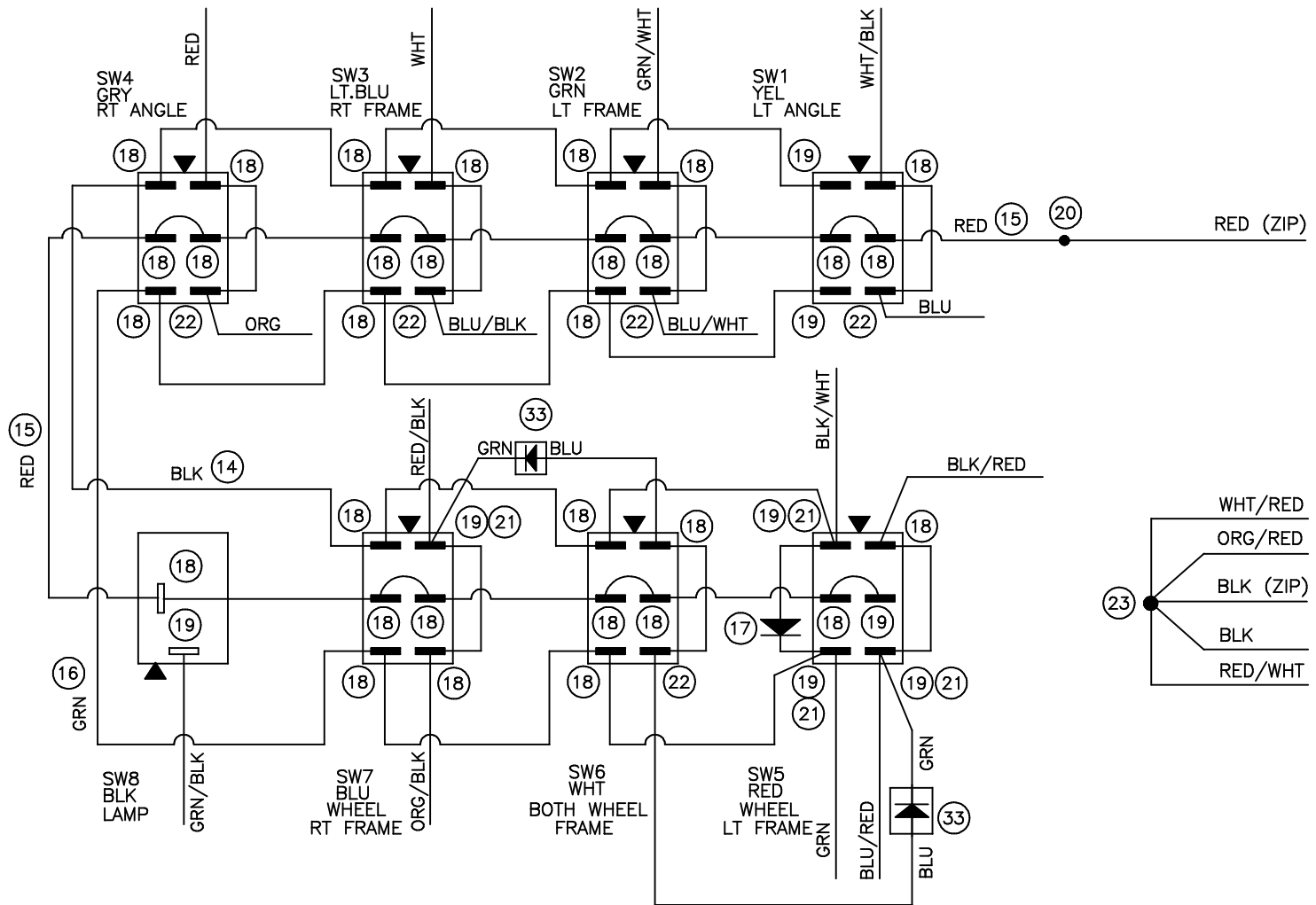

▲ = NOTCH LOCATION

UNLESS OTHERWISE SPECIFIED: DIMENSIONS ARE IN INCHES TOLERANCES ON: 2 PL. DECIMALS 3 PL. DECIMALS ANGLES FRACTIONS	SIGNATURES	DATE	FASSE VALVES SEVEN ROYAL PARK KEARNEY, NE 68848-2348
	DRAFTER DLG	08/07/13	
ENGRG BWL	08/07/13	SIZE FSCM NO A	DWG NO 312-081
THIS DRAWING IS A PROPRIETARY DESIGN OWNED BY FASSE CORPORATION/FASSE VALVES AND IS SUBMITTED UNDER A CONFIDENTIAL RELATIONSHIP. EXCEPT FOR USES EXPRESSLY GRANTED IN WRITING, ALL RIGHTS ARE RESERVED BY FASSE VALVES.			SCALE SHEET 2 OF 2

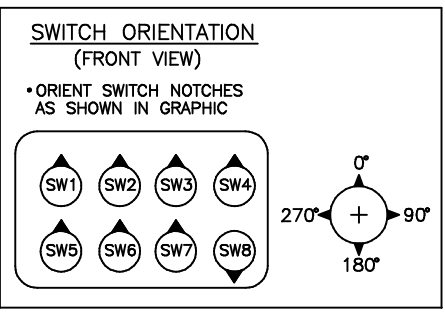
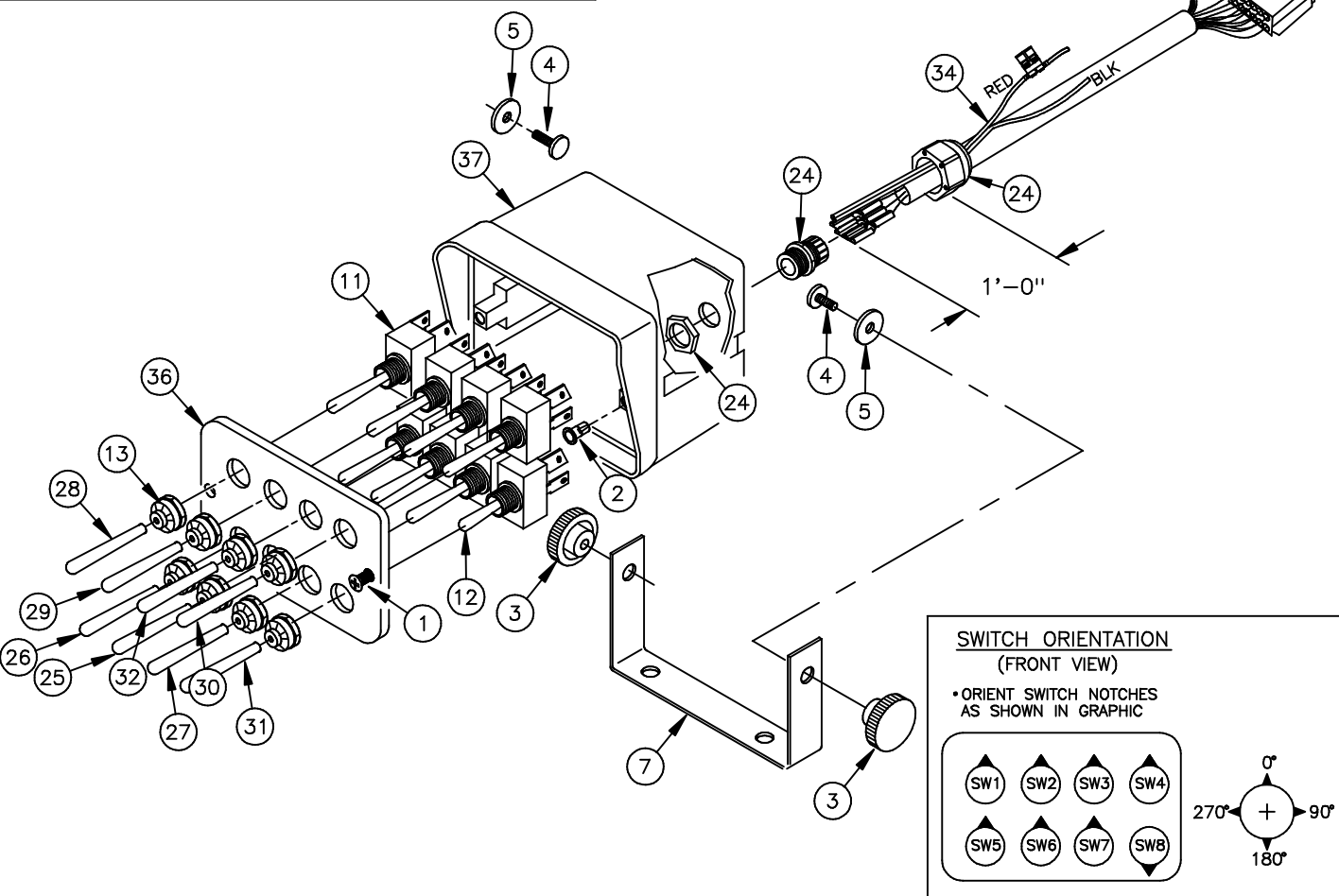
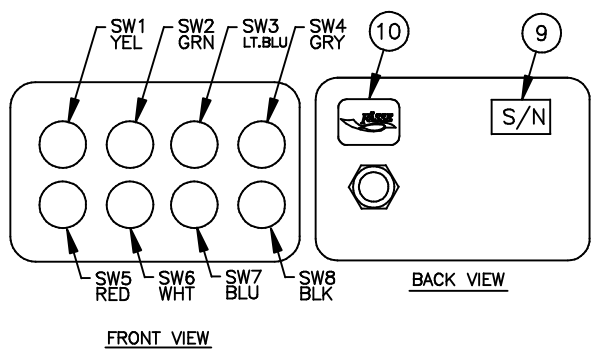

PARTS LIST			
Nº	PART NUMBER	QTY	PART DESCRIPTION
1	212-184	2	SCREW 6-32 X 3/8 OVAL HD BLK
2	212-202	2	INSERT 6-32X3/8 BRASS
3	212-215	2	KNOB 1/4-20 FEMALE
4	212-231	2	SCREW WELDED 1/4-20 X .500
5	213-335	2	WASHER NYLON .257X.875X.060
6	214-004	14	CABLE TIE BLACK 7"
7	219-300	1	BRKT HSNG MONITOR
8	230-057	1	BAG POLY 14 X 18 2MIL LOGO
9	232-050	2	DECL S/N (SILVER)
10	232-058	1	DECAL FASSE BLK/GOLD 1" X .75" RND CRNR
11	250-013	7	SW TOG DPDT 3P MOM LONG
12	250-020	1	SW TOG SPST 2P STAT SHORT
13	250-023	8	SW TOG BOOT OPN GRY
14	252-058	1'	WIRE 18GA BLACK
15	252-059	1'	WIRE 18GA RED
16	252-060	1'	WIRE 18GA GREEN
17	254-001	1	DIODE D116A2 6AMP
18	255-002	31	TRM PO T-TAP F 18-14GA
19	255-006	8	TRM PO F NON INS 20/18GA
20	255-030	1	TRM SPLICE CLOSED END
21	255-070	4	TRM PO M/F
22	255-119	5	TRM PO F INS 16-14GA
23	255-285	1	TRM SPLICE CLOSED END LRG 14-16GA
24	255-710	1	STRAIN RLF HEYCO .45"-.705"ID, HOLE DIA 1.115"
25	259-004	1	SW TOG GRIP VNYL WHT .187
26	259-005	1	SW TOG GRIP VNYL RED .187
27	259-015	1	SW TOG GRIP VNYL BLU .187
28	259-022	1	GRIP TOG VNYL YEL .187"
29	259-023	1	SW TOG GRIP VNYL GRN .187
30	259-027	1	GRIP TOG VNYL GRY .187"
31	259-031	1	GRIP TOG VNYL BLK .187"
32	259-044	1	GRIP TOG VNYL LIGHT BLUE .187"
33	300-327	2	DIODE ASSY 6A05/1/INTERNAL
34	304-594	1	HRN 2CON 16GA R/B ZIP 10A FUSE 7"
35	312-082	1	HRN 19CON 18GA DTP 12P(11) DTP8P(7) 6'
36	312-083	1	ENCL FP DRILL MNTR SW8 NIKKEL IRON
37	319-786	1	ENCL DRILL MNTRBX 1 1/8" STR RLF

**NOTES:**

- USE 1-CABLE TIE TO COIL UP HARNESS
- NOT SHOWN: (6) (8)

REVISIONS					UNLESS OTHERWISE SPECIFIED		SIGNATURES		DATE
REV	DESCRIPTION	FORM #	DATE	APPROVED	DRW	ENGR	DATE		
	RELEASED DRAWING	13-0065	06/07/13	DLG	ENL		06/07/13		
A	UPDATED DRAWING	13-0065	12/17/13	DLG	ENL				
B	REV 20-02, 21-02, 22-02, 23-02, 24-02, 25-02, 26-02, 27-02, 28-02, 29-02, 30-02, 31-02, 32-02, 33-02, 34-02, 35-02, 36-02, 37-02	15-0061	6/10/15	LFL	ENL		06/07/13		

DIMENSIONS ARE IN INCHES		TOLERANCES ON:	
2 PL DECIMALS		3 PL DECIMALS	
ANGLES		FRACTIONS	

THIS DRAWING IS A PROPRIETARY DESIGN OWNED BY FASSE CORPORATION/FASSE VALVES AND IS SUBMITTED UNDER A CONFIDENTIAL RELATIONSHIP. EXCEPT FOR USES EXPRESSLY GRANTED IN WRITING, ALL RIGHTS ARE RESERVED BY FASSE VALVES.	SIZE: A	FSCM NO:	DWG NO: 312-081
	SCALE:		SHEET 1 OF 2

PARTS LIST			
NO	PART NUMBER	QTY	PART DESCRIPTION
1	232-195	1	DECAL MNTR DARF 6CIR
2	251-131	1	ENCL FACEPLATE MONITOR 88X133

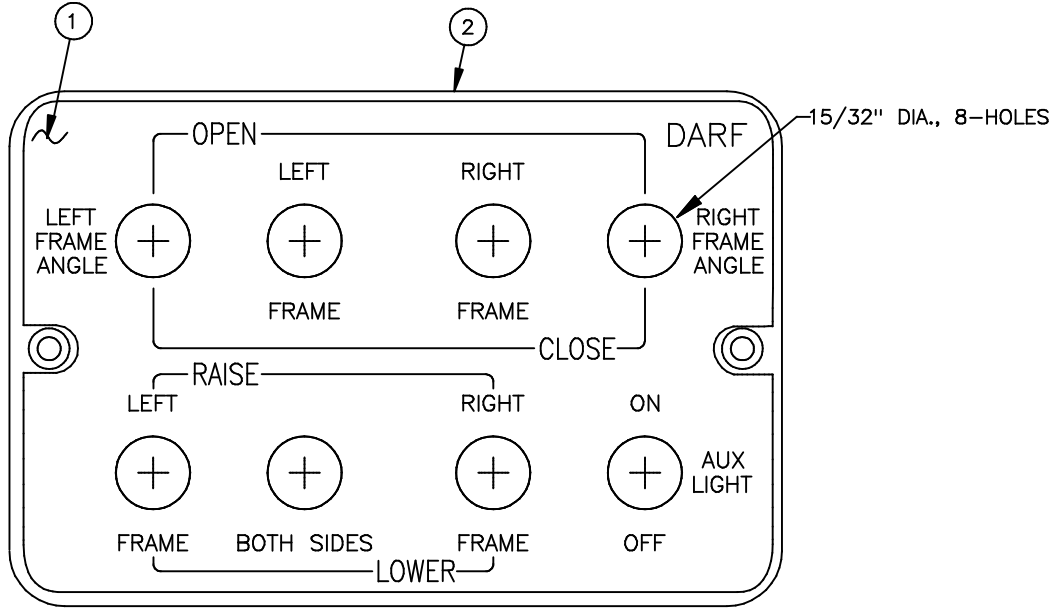

**NOTE:**  
 CENTER DECAL ON FACEPLATE THEN  
 DRILL HOLES ACCORDING TO DECAL.

REVISIONS					UNLESS OTHERWISE SPECIFIED		SIGNATURES		DATE	
REV	DESCRIPTION	FORM #	DATE	APPROVED	DIMENSIONS ARE IN INCHES TOLERANCES ON:		DRAWN	DATE	FASSE VALVES	
	RELEASED DRAWING	13-0065	06/07/13	DLG   BWL	2 PL. DECIMALS 3 PL. DECIMALS ANGLES FRACTIONS		DLG	06/07/13	SEVEN ROVAR PARK KEARNEY, NE 68848-2348	
							ENGRG	06/07/13	ENCL FP DRILL MNTR SW8 NIKKEL IRON	
THIS DRAWING IS A PROPRIETARY DESIGN OWNED BY FASSE CORPORATION/FASSE VALVES AND IS SUBMITTED UNDER A CONFIDENTIAL RELATIONSHIP. EXCEPT FOR USES EXPRESSLY GRANTED IN WRITING. ALL RIGHTS ARE RESERVED BY FASSE VALVES.								FSCM NO		DWG NO
										312-083
								SCALE		SHEET



PARTS LIST

REF.	PART NO.	QTY.	DESCRIPTION
1	212-108	1	BOLT 1/4"-20X.5"
2	213-442	1	NUT HEX NYLON 1/4"-20
3	219-016	1	MAG CERAMIC RND 3.25" DIA DL 18"
4	230-002	1	BAG POLY 9X12 3MIL
5	230-016	1	BAG POLY 4X6 2MIL
6	231-250	1"	SHRINKTUBING .250" BLK
7	251-093	1	FLOOD LIGHT 6LED 12V 18W 4.75" DIA
8	255-969	1	CONN DEUT LOCK WEDGE 2PIN DTR GRN
9	255-971	1	CONN DEUT DT RCPT 2PIN
10	255-977	2	CONT DEUT PIN 16-18GA

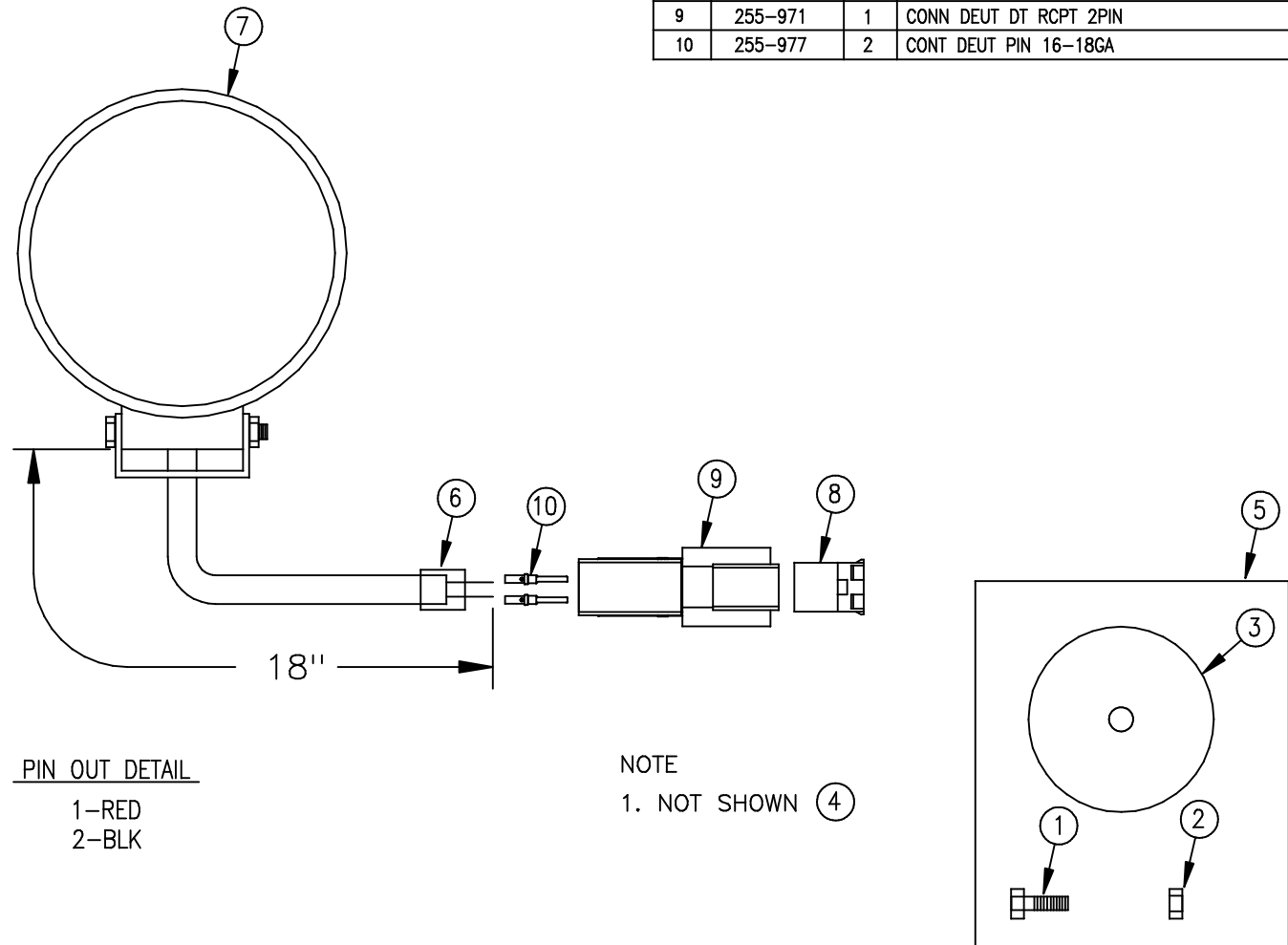

PIN OUT DETAIL

1-RED  
2-BLK

NOTE

1. NOT SHOWN (4)

REVISIONS					UNLESS OTHERWISE SPECIFIED	SIGNATURES	DATE	 <b>FASSE VALVES</b> SEVEN ROVAR PARK KEARNEY, NE 68848-2348
REV	DESCRIPTION	FORM #	DATE	APPROVED	DIMENSIONS ARE IN INCHES	DRAFTER	DATE	
	RELEASED DRAWING	13-0065	08/12/13	DLG BWL	TOLERANCES ON:	DLG	08/12/13	
A	REVISED DRAWING	13-0065	5/14/14	DLG BWL	2 PL DECIMALS	ENGRG	08/12/13	
B	231-250 WAS 231-313	15-0057	7/29/15	LFL BWL	3 PL DECIMALS ANGLES FRACTIONS			
					THIS DRAWING IS A PROPRIETARY DESIGN OWNED BY FBS CORPORATION/FASSE VALVES AND IS SUBMITTED UNDER A CONFIDENTIAL RELATIONSHIP. EXCEPT FOR USES EXPRESSLY GRANTED IN WRITING, ALL RIGHTS ARE RESERVED BY FASSE VALVES.			